



Gunclean Toftejorg i270

Tank and hold cleaning machine

The Gunclean Toftejorg i270 is a fully programmable turbine driven single nozzle tank cleaning machine. i270 is the next generation of our hard proven 270 FT Mark I machine.

Improvements

- Upgraded gearbox. More maintenance friendly.
- New nozzle design.
 - Ball instead of slide bearings. Less torque means less wear in gearbox.
 - Less leakage flow and longer throw length. Higher cleaning effect/less water capacity need for cleaning.
 - Longer time between maintenance.

Application

The Gunclean Toftejorg i270 is designed for fixed installations onboard crude oil, bulk, product carriers, and FPSO's.

Operation

The Gunclean Toftejorg i270 will immediately be in operation for cleaning by just opening the supply valve. An easy selection between four different cleaning programmes is offered, from quick cleaning to tight pitch cleaning for heavy duty. All programmes are available by turning the knob on the power unit before or during cleaning. Nozzle position can be adjusted either before or during operation. The rotation speed can be set between 1–2 rpm.

Cleaning pattern

The nozzle performs a helical cleaning pattern. The power unit is designed to give a tighter cleaning pattern in the bottom of the tank or hold, where it is generally most needed.

Options

- Inlet flange according to JIS and ANSI standard.
- Deck flange with customized dimensions.
- Split extension pipe.
- Sensor connection for all cargo control systems.
- Gasket and sealings.
- Strainer in flange.
- Nozzle turning angle from 0° to 165° and –45° to 180°.
- Epoxy coated inlet house.
- Extension pipe made in stainless steel AISI 316L.

Regulations

The equipment fully complies with IMO regulations and the requirements of the classification societies.



Gunclean Toftejorg i270.

Specifications

Materials, main parts (standard version)

Inlet housing	Ductile cast iron, hot galvanized
Extension pipe	Carbon steel, hot galvanized
Lower assembly	Stainless steel AISI 316
Cover	Stainless steel & coated
Sealings	Viton/Nitril

Weight

Machine with 1.0 m length of main pipe	95 kg
Per additional metre of main pipe	20 kg
(Standard version up to 4 metres ext. pipe)	

Lubricant	Oil or grease
Working pressure	7–12 bar (105–195 psi)
Capacity	30–120 m ³ /hour
Max. working temperature	85°C (185°F)
Programmable pitch	4 different settings from 1°–8.5°
Nozzle turning angle	0°–180°

Sealings

Gas	0–0.5 bar (0–7.5 psi)
Water/oil	0–13 bar (0–195 psi)

Installation	Fixed
--------------	-------

Cleaning pattern

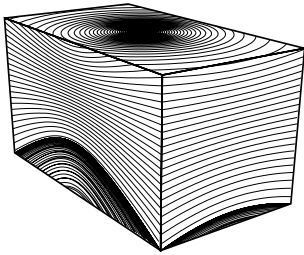

Dense pattern

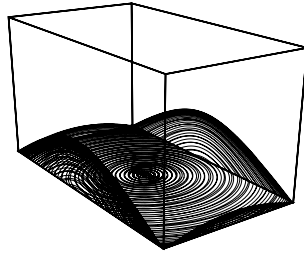

Bottom pattern

Dimensions (mm)

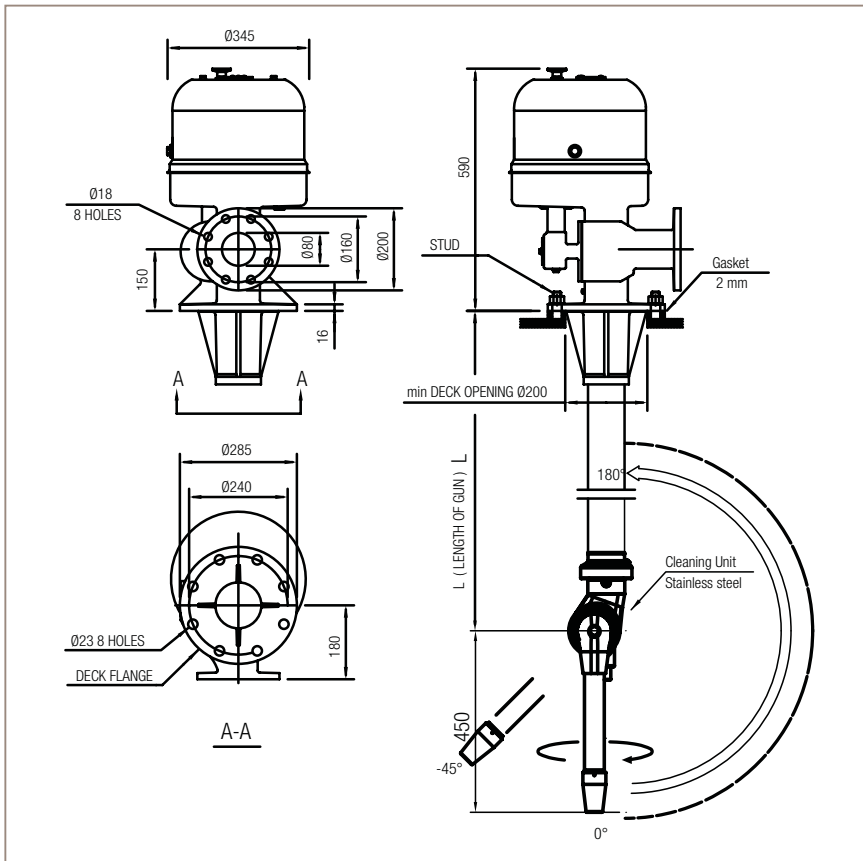

**Performance data:
Flow rate, nozzles $\varnothing 17-32$**

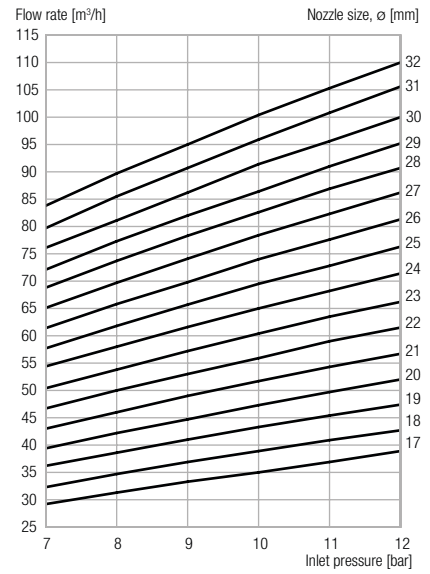

Recommended design throw length at static condition

